

Segregation of HLA in Sibs with Cleft Lip or Cleft Lip and Palate: Evidence Against Genetic Linkage

DON C. VAN DYKE, M.D.
ALLEN S. GOLDMAN, M.D.
RICHARD S. SPIELMAN, Ph.D.
CHESTER M. ZMIJEWSKI, Ph.D.
SEISHI W. OKA, D.D.S., Ph.D.

Philadelphia, Pennsylvania 19104

The segregation of *HLA haplotypes* (A, B, and C loci) was studied in eight families in which two sibs were affected with *cleft lip* or *cleft lip and palate*. HLA typing was performed in parents and sibs and in specific cases, other family members. Segregation of HLA haplotypes did not differ significantly from random Mendelian expectation. Three of the eight affected sib pairs differed in both HLA haplotypes, which is not expected if there is close *linkage* with susceptibility to clefting. Thus, it is very unlikely that spontaneous cleft lip or cleft lip and palate is closely linked to HLA.

Introduction

One in every 650 children in the United States is born with cleft lip or cleft lip and associated cleft palate. We use "cleft lip (palate)" to designate the combination of these two categories. This congenital malformation accounts for approximately 13% of all reported birth defects (Pruzansky et al., 1973). A genetic component is universally accepted.

Dr. Van Dyke and Dr. Spielman are affiliated with the Department of Human Genetics, University of Pennsylvania, School of Medicine, Philadelphia, Pennsylvania 19104. Dr. Van Dyke is also affiliated with the Children's Seashore House Clinical Genetics Center, The Children's Hospital of Philadelphia, 34th Street and Civic Center Boulevard, Philadelphia, Pennsylvania 19104. Dr. Goldman is affiliated with The Division of Teratology and Department of Pediatrics, The Children's Hospital of Philadelphia. Dr. Zmijewski is affiliated with the Department of Pathology, Hospital of the University of Pennsylvania, 3400 Spruce Street, 6th West Gates Building, Philadelphia, Pennsylvania and Dr. Oka is affiliated with The Lancaster Cleft, Palate Clinic 24 North Lime Street, Lancaster, Pennsylvania 17602.

This research was supported in part by grants 1-491 "The National Foundation-March of Dimes"; DE-4622, and DE-5041 National Institute of Dental Research; and AM-19525, National Institutes of Health. DCVD is supported by Postdoctoral Training Grant, T32-GM07511-05. SWO is a recipient of a Special Dental Research Award, DE-04537-03. Lancaster Cleft Palate Clinic is a recipient of a National Institute of Dental Research Program Grant, DE-02172-13.

Fraser and Fainstat (1951), in a study of palatal clefting in the mouse, observed that susceptibility to corticoid-induced cleft palate varied according to strain. The A/J strain mouse, which is also known to have an increased background rate for cleft lip (palate) (Kalter, 1969), was shown to have a greater susceptibility to corticoid-induced cleft palate than the resistant C57BL16 strain.

Several investigators have obtained data indicating that a gene involved in susceptibility to cortisone-induced cleft palate in these mice is linked to the *H-2* region or major histocompatibility complex (Bonner and Slavkin, 1975; Biddle and Fraser, 1977; Tyan and Miller, 1978). The differences among inbred strains of mice in susceptibility to cortisone-induced cleft palate have been attributed to genetically determined differences in fetal facial mesenchymal glucocorticoid receptor levels (Salomon and Pratt, 1976; Goldman et al., 1977; Goldman and Katsumata, 1978).

The human counterpart of the mouse *H-2* complex is the HLA region (Ivanyi, 1978) on chromosome 6 (Lamm et al., 1974), and although there is no evidence cited above to suggest that a hypothetical major gene for spontaneous cleft lip (palate) might be linked to the HLA locus in man, the fact that several such linkages have been established for other

traits led us to investigate this question. Standard methods for detecting linkage are not applicable to traits or disorders which, like cleft lip (palate), do not show classical Mendelian segregation. Instead, several special tests for linkage in this situation have been developed. All tests are based on the principle that, if there is close linkage, affected sibs in the same family should show a non-random distribution of the HLA haplotypes present in the parents. The rationale for this test is given in the Material and Methods section.

Analysis of HLA haplotype segregation in affected sibs has established genetic linkage between HLA and various diseases of complex but poorly understood etiology (Bodmer, 1978). Very close linkage has also been shown between the HLA region, especially the HLA B locus, and the gene locus for the corticoid-synthesizing enzyme, 21 hydroxylase (Dupont et al., 1977; Levine et al., 1978). Deficiency of this enzyme results in congenital adrenal hyperplasia, which is inherited as a classical autosomal recessive. Encouraged by these successful demonstrations of linkage, we have sought to use segregation analysis in families with multiple affected sibs to determine whether a locus for susceptibility to cleft lip (palate) is closely linked to HLA.

Material and Methods

PATIENTS:

The sample studied consisted of eight families in which at least two sibs have cleft lip (palate). The patients were ascertained via cleft palate clinics in Pennsylvania and New Jersey. The precise malformations were determined from clinic records and confirmed by individual interviews. One patient had cleft lip with submucous cleft of the palate. All the remaining patients had cleft lip alone or cleft lip with associated cleft palate. Families with other craniofacial malformations e.g., Pierre Robin anomalad, were excluded from this study. Velopharyngeal incompetence and bifid uvula were not accepted as evidence of cleft palate.

TYPING FOR HLA

Blood was drawn from each family member for typing of the A, B, and C specificities of the HLA system. HLA typing was performed

on peripheral blood lymphocytes by the standard National Institutes of Health 2-Stage Micro-Cytotoxicity method described by Mittal et. al., (1968). One hundred and ten antisera capable of detecting most of the recognizable HLA antigens were used. The sera were obtained from the NIH-NIAID Sera Bank, our own collection of sera from multiparous women and as gifts from other investigators.

ANALYSIS

Under the null hypothesis of no linkage between the HLA region and the locus for susceptibility to cleft lip (palate), parental HLA haplotypes ab and cd should segregate in the offspring as ac, ad, bc, and bd so that, on the average, 25% of sib pairs will be HLA identical (share both haplotypes), 50% will be haploidentical (share only one haplotype), and 25% will be completely different (share neither haplotype). If there is genetic linkage, however, a departure from this random segregation is expected, and there should be a deficit in the proportion of affected sib pairs sharing neither haplotype (Thomson and Bodmer, 1977). If there is very close linkage with HLA, this proportion should be close to 0 (1-5%), unless the allele for susceptibility is very common (Thomson and Bodmer, 1977). Thus, a small number of affected sib pairs provide a powerful test for close linkage, and linkage between HLA and susceptibility to a number of diseases has been demonstrated in this way (for example, see Bodmer, 1978).

Results

The segregation of HLA haplotypes in eight families with cleft lip (palate) is presented in Table 1 and Figure 1. In three of the sibships (C-2, S-2, and Y-1), the affected sibs share neither haplotype. The pattern of shared haplotypes observed in this study is summarized in Table 2. It does not depart significantly from Mendelian segregation of HLA and, therefore, is inconsistent with close linkage between cleft lip (palate) and the HLA region. It is particularly noteworthy that there is no deficiency of affected sib pairs sharing neither haplotype. Thus, the gene(s) determining susceptibility to spontaneous cleft lip (palate) are probably not located close to the HLA region on chromosome 6.

TABLE 1. HLA Genotypes in 8 Families with Cleft Lip (Palate)

Family Code	Haplotypes						
	a	b	c	d	e	f	g
B-1	All, BW35	AW23 (9), B12	A26 (10), B12	A2, B40	—	—	—
C-1	A3, B7	*-, B27	A28, B27	AW30, B13	A2, B18	A1, -	—
C-2	A1, B8	A3, B14	A1, B17	AW32, B27	—	—	—
D-1	A1, B8	AW24 (9), BW35	A1, B8	A2, BW21	—	—	—
S-1	A2, B7	AW31, B40	A2, B7	A2, B15	AW24 (9), B40	A1, B8	A3, B7
S-2	A26 (10), B38 (16), CW3	A2, B40, CW3	A1, BW35	AW24 (9)	—	—	—
W-1	AW32, B12	A10, -	A10, -	A2, B8	—	—	—
Y-1	A2, B7	AW23 (9), B40	AW24 (9), B12	A2, BW22	—	—	—

* Note: Genotypes containing “-” are homozygous or correspond to antigens not recognized by available antisera.

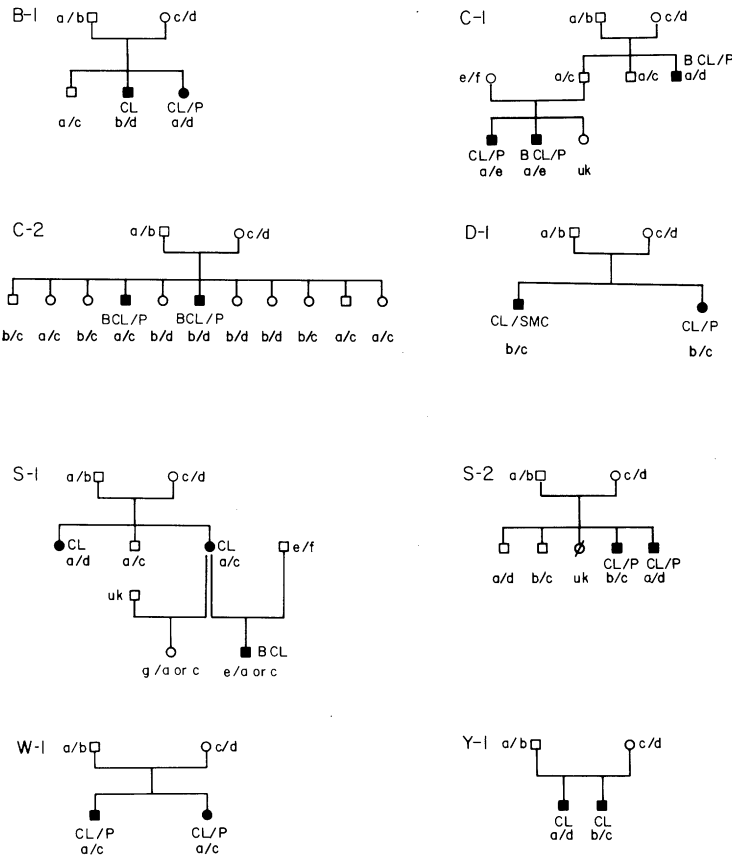

FIGURE 1. HLA Haplotypes in eight families with cleft lip (palate) in two or more members, represented by solid symbols. Paternal haplotypes— a and b, maternal haplotypes— c and d correspond to genotypes in Table 1; HLA types unknown (not tested)—uk. CL—cleft lip; BCL—bilateral cleft lip; CL/P, BCL/P—with associated cleft palate. SMC—submucous cleft.

Discussion

It is well known that various diseases (Dausset and Svegaard, 1977) including some con-

genital heart malformations (Buc et al., 1975) show associations with certain HLA antigens i.e., some antigens are found with significantly higher frequency in patients than in controls.

TABLE 2. Segregation of HLA Haplotypes Among Affected Sibs with Cleft Lip or Cleft Lip and Palate

<i>Shared Haplotypes</i>	<i>Observed Distribution</i>	<i>Expected Distribution</i>
2 shared	3	2
1 shared	2	4
0 shared	<u>3</u>	<u>2</u>
Total	8	8

We are aware of only two studies which bear on the issue of such associations for cleft lip (palate). Families with a single cleft lip (palate) patient were studied by Rapaport et al., (1973a, 1973b), but the published reports focus on a different problem, and HLA typing results are given for fewer than 10 patients. Bonner et al. (1978) found a non-significant increase ($P > 0.05$) of HLA-AW24 and A28 in males but not females with cleft lip (palate) studied in Southern California. It is clear, however, that linkage between disease susceptibility and HLA may exist and can be detected even in the absence of a population association. In congenital adrenal hyperplasia, family studies have established extremely close linkage with HLA-B, but there appears to be no association with particular HLA antigens when unrelated patients are studied (Levine et al., 1978).

It appeared therefore that family studies might provide direct evidence for or against linkage between cleft lip (palate) and HLA. Furthermore, it has been shown that susceptibility to cortisone-induced cleft palate is linked to *H-2* in the mouse (Bonner and Slavkin, 1975; Tyan and Miller, 1978). Thus, linkage with the human evolutionary homologue HLA seemed a possibility. However, our data on affected sib pairs make the existence of HLA-linked genes for cleft lip (palate) unlikely.

The observations in the A/J mice, however, pertain to *isolated* cleft palate, and may not be applicable to cleft lip (palate) in humans. Isolated cleft palate in humans has long been considered to be etiologically (genetically) distinct from cleft palate associated with cleft lip (Fraser, 1970). Moreover, the *H-2*-linked susceptibility in the mouse is for cortisone-induced cleft palate. Thus, we are left with the two possibilities which merit further investigation. First, the present results do not rule

out the possibility that isolated cleft palate in man is linked to HLA. To determine whether this is so, we are currently studying the segregation of HLA types in families with sibs affected with cleft palate (without cleft lip). Second, extrapolation from the mouse model suggests that additional studies need to be performed on the relationship between HLA and susceptibility to cleft palate induced by environmental factors.

Acknowledgments: We thank Gloria McAllister, Children's Hospital of Philadelphia; Rena Canavan and William Sullivan, Hospital of the University of Pennsylvania; and Linda Landers, Harrisburg Hospital, for technical assistance. We acknowledge the cooperation and assistance of the following cleft palate clinics: 1) Children's Hospital of Philadelphia Cleft Palate Clinic; 2) Cleft Palate Clinic of Wilkes-Barres/Scranton; 3) Allentown Cleft Palate Clinic; 4) Lancaster Cleft Palate Clinic; 5) Williamsport Cleft Palate Clinic; and 6) Reading Cleft Palate Clinic.

Allen S. Goldman, M.D.

Research Professor of Pediatrics & Pharmacology
Division of Teratology
The Children's Hospital of Philadelphia
34th Street & Civic Center Boulevard
Philadelphia, PA 19104

References

- BIDDLE, F. G., 2nd, and FRASER, F. C., Cortisone-induced cleft palate in the mouse. A search for the genetic control of the embryonic response trait, *Genetics*, 85, 289-302, 1977.
- BODMER, W. F., The HLA System, *Brit. Med. Bull.*, 34, 213-324, 1978.
- BONNER, J. J., and SLAVKIN, H. C., Cleft palate susceptibility linked to histocompatibility-2 (*H-2*) in the mouse, *Immunogenetics*, 2, 213-218, 1975.
- BONNER, J. J., TERASAKI, P. I., THOMPSON, P., HOLVE, L. M., WILSON, L., EBBIN, A. J., AND SLAVKIN, H. C., HLA phenotype frequencies in individuals with cleft lip and/or cleft palate, *Tissue antigens*, 12, 228-232, 1978.
- BUC, M., NYULASSY, S., STEFANOVIC, J., JAKUBCOVA, I., and BENDEKOVA, M., HL-A2 and congenital heart malformations, *Tissue Antigens*, 5, 128-130, 1975.
- DAUSSET, J., AND SVEJGAARD, A., (Eds.), HLA AND DISEASE. COPENHAGEN: MUNKSGAARD, 1977.
- DUPONT, B., SMITHWICK, E. M., OBERFIELD, S. E., LEE, T. D., and LEVINE, L. S., Close genetic linkage between HLA and congenital adrenal hyperplasia (21-hydroxylase deficiency), *The Lancet*, 2, 1309-1311, 1977.
- FRASER, F. C., and FAINSTAT, T. D., Production of congenital defects in the offspring of pregnant mice treated with cortisone, *Pediatrics*, 8, 527-533, 1951.

- FRASER, F. C., The genetics of cleft lip and cleft palate, *The Amer J Human Gent.*, 22, 336-352, 1970.
- GOLDMAN, A. S., and KATSUMATA, M., Quantitative variation in hormonal receptors and clefting in the mouse. *State of the Art Workshop*, Airlie House, 1979 (in press).
- GOLDMAN, A. S., SHAPIRO, B. H., and KATSUMATA, M., Human foetal palatal corticoid receptors and teratogens for cleft palate, *Nature*, 272, 464-466, 1978.
- IVANYI, P., Some aspects of the H-2 system, the major histocompatibility system in the mouse, *Proceedings of the Royal Society, London*, 202, 117-158, 1978.
- KALTER, H., Sporadic congenital malformations of newborn inbred mice, *Teratology*, 1, 193-200, 1968.
- LAMM, L. U., FRIEDRICK, U., PETERSEN, G. B., JORGENSEN, J., NIELSEN, J., THERKELSEN, A. J., and KISSMEYER-NIELSEN, F., Assignment of the major histocompatibility complex to chromosome 6 in a family with a pericentric inversion, *Human Heredity*, 24, 273-284, 1974.
- LEVINE, L. S., ZACHMANN, M., NEW, M. I., PRADA, A., POLLACK, M. S., O'NIELL, G. J., YANG, S. Y., OBERFIELD, S. E., and DUPONT, B., Genetic mapping of the 21-hydroxylase-deficiency gene within the HLA linkage group, *New England J Med.*, 299, 911-915, 1978.
- MITTAL, K. K., MICKEY, M. R., SINGAL, D. P., and TERASAKI, P. I., Serotyping for homotransplantation XVIII. Refinement of microdroplet lymphocyte cytotoxicity test, *Transplantation*, 6, 913-927, 1968.
- PRUZANSKY, S., CLIFFORD, E., CONVERSE, J. M., JOHNSTON, M. C., LANGMAN, J., LIS, E. F., SLAVKIN, H. C., and WARKANY, J., Report of the ad hoc advisory committee on program strategies for research on craniofacial anomalies, 1973.
- RAPAPORT, F. T., BACHVAROFF, R., CONVERSE, J. M., RAISBECK, A. P., AYVAZIAN, J. H., SEGALL, M., and BACH, F. H., Typical patterns of inheritance of the serologically detectable (SD) products of the HL-A complex in human developmental anomalies, *Transpl. Proc.*, 5, 1817-1822, 1973(a).
- RAPAPORT, F. T., BACHVAROFF, R., CONVERSE, J. M., RAISBECK, A. P., AYVAZIAN, J. H., SEGALL, M., and BACH, F. H., Genetic studies of mixed leukocyte culture reactivity in human developmental anomalies, *Transpl. Proc.*, 5, 1823-1830, 1973(b).
- SALOMON, D. S., and PRATT, R. M., Glucocorticoid receptors in murine embryonic facial mesenchyme cells, *Nature*, 264, 174-177, 1976.
- THOMSON, G., and BODMER, W. F., The genetic analysis of HLA and disease associations. In: *HLA and Disease*, Dausset, J., and Svejgaard, A., (Editors). Copenhagen: Munksgaard, 84-93, 1977.
- TYAN, M. L., and MILLER, K. K., Genetic and environmental factors in cortisone-induced cleft palate, *Proceed. Soc. Experimental Biol. and Med.*, 158, 618-621, 1978.